

WARNING

EXTREME CARE MUST BE USED FOR YOUR SAFETY

PLANNING

Plan your installation carefully. If you use volunteer helpers be sure that they are qualified to assist you. Make certain that everyone involved understands that you are the boss and that they must follow your instructions. If you have any doubts at all, employ a professional antenna installation company to install your antenna.

POWER LINES

This antenna is an electrical conductor. Contact with power lines can result in death, or serious injury. Do not install this antenna where there is any possibility of contact with or high voltage arc over from power cables or service drops to buildings. The antenna, supporting mast and/or tower must not be close to any power lines during installation, removal or in the event part of the system should accidentally fall. Follow the guidelines for antenna installations recommended by the U.S. Consumer Product Safety Commission.

CONTACT WITH ANTENNA AND RF

You must insure that while the hexagonal beam is in operation neither people or pets can come in contact with any portion of your antenna. Deadly voltages and currents may exist. Also, since the effects of exposure to RF fields are not fully understood, long term exposure to intense RF fields is not recommended.

SYSTEM GROUNDING

Direct grounding of the antenna mast and tower is very important. This serves as protection from lightning strikes and static buildup, and from high voltage which is present in the radio equipment connected to the antenna. A good electrical connection should be made to one or more ground rods (or other extensive ground system) directly at the base of the tower or mast, using at least #10AWG ground wire and noncorrosive hardware. For details and safety standards, consult the National Electrical Code. You should also use a coaxial lightning arrester.

For the safety of users, this pamphlet is provided with every hexagonal beam sold by KIO Technology LLC.



G3TXQ Broadband Hexagonal Beam
By K4KIO

Assembly Instructions v5.6
January 2012

ASSEMBLY INSTRUCTIONS

G3TXQ Broad Band Hexagonal Beam by K4KIO v5.6
January 2012

Introduction:

You have purchased a G3TXQ broad band hexagonal beam built by K4KIO. This beam can be assembled in an evening with only a few hand tools. All wires and tip spacers have been pre-set and no tuning is needed to have great performance. You need little technical expertise to assemble this beam. You do need a license from the FCC to transmit with it in the USA.

It is very important to follow these instructions in order to avoid damaging your hexagonal beam particularly by over tightening or over stressing the components in the assembly process.

Tools Needed:

- Med. Screwdriver for spreader clamps
- Pliers for closing S hooks on support cords
- End wrench for the U bolt nuts
- 3/16 " Allen wrench (supplied)
- gloves

Components Included:

1. Base plate and two flanges with 12 stainless steel U-bolts and lock nuts with nylon inserts



2. All metal, coaxial aluminum center post with new design that requires no wiring harness. An SO 239 UHF coax chassis socket is on the back of the post at the top.



3. Six fiberglass spreader arms of three telescoping sections for each. Equipped with clamps and aluminum cushioned P clips for attaching wire sets.



4. Wire/tip space assemblies separately bagged and labeled for each band. Wires and tip spacers are pre-measured and assembled, ready for installation on the hexagonal frame. The wire is pvc insulated #14 168 strand Flex weave.

5. Seven Kevlar/Dacron covered support cords (all the same size) with stainless steel end hooks



installed and one smaller intermediate cord.

6. Miscellaneous hardware consisting of UV resistant cable ties and a 3/16 inch hex key for the set screws on the base plate flanges.

Assembly:

1. Six meter add-on

A. If you ordered six meters with your beam, you should install the wire attachments at the mark on the six largest spreader sections (1 inch thick) as shown on the sketch in the six meter wire kit.

2. Spreaders **(Use gloves in handling these spreaders to avoid fiberglass residue)**

A. Insert the six large spreader sections (1 inch thick) into the U-bolts on the base plate. All these six spreader sections are identical.

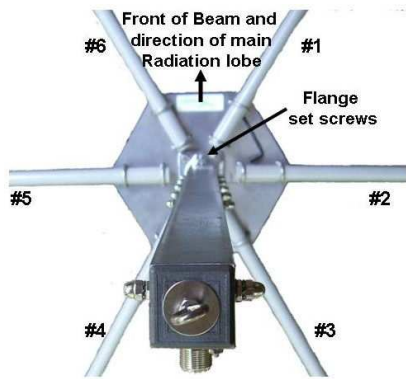

B. Tighten the U bolt nuts on the bottom of the base plate but be careful not to over tighten as you might crush the spreaders. If you see the spreader being flattened against the base plate, you are tightening it too much.

Tip: (Look across the beam to see if a spreader is lined up with its opposite. If not, then re-adjust the nuts on the U bolts to make them more even.)

C. Arrange a temporary stand for assembling the rest of the beam. A large 10 gallon paint bucket turned right side up, with bricks, sand or other weights in it that you can set the beam on will work or a one inch pipe stuck in the ground. You will want the spreaders to be fairly level as you install the wire/tip space assemblies.

D. Insert each of the six medium spreader sections (3/4 inch thick) into the end of a larger spreader and push it up to the stop clamp on the medium spreader. When pushing the sections together be sure the P clips are on the upper side of the spreaders.

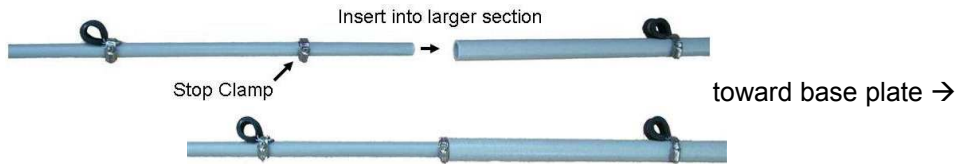

E. Insert each of the six small spreader sections (1/2 inch thick) into the end of a medium spreader and push up to the stop clamp.

F. The spreader sections will be kept together by the tension of the support cords and can be easily taken apart for portability. However, if you wish, you can attach them permanently by the use of general purpose adhesive such as Liquid Nail. Or you can drill a small hole through the ends that are telescoped and use a small #6 machine bolt. But neither is necessary for the beam to hold together adequately.

3. Center post



A. Insert the center post into the base plate and turn it so that the white KIO logo label on the post is toward the KIO logo label on the base plate. This is the front of the beam and the direction of the main beam lobe. The coax will connect on the back of the center post and come down through the hole in the base plate.

B. Tighten the set screws on the flange using the 3/16" hex key supplied. Do not over tighten the center post.

4. Support Cords

A. Hook a support cord to the end of a spreader and pull it toward the center post and let it lie on the ground loose.

B. Hook another support cord to end of the opposite spreader from Step 4.A. and pull it toward the center post.

Now grip the loose ends of both support cords and pull them together until you can hook both over the eye bolt on the top of the center post at the same time. The idea of pulling two spreaders up at the same time is to avoid unnecessary stress on the center post.

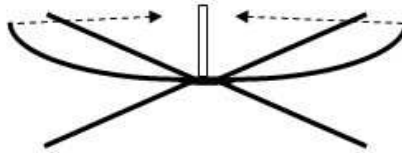

C. Repeat this with another pair of spreaders and support cords and then again until all six spreaders and support cords are attached to the center post.

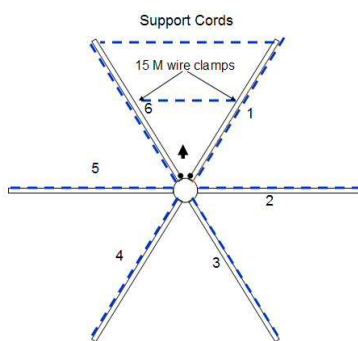

D. There are two remaining support cords. Hook the larger one between the ends of spreaders 1 and 6. The remaining small support cord will be attached later after the wires have been installed. Dashed lines at left show the cords.

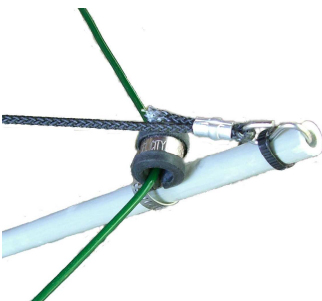

E. Fasten the hooks on the ends of the spreaders with the large cable ties supplied as shown here.

F. With pliers, squeeze all the hooks closed on the post top ring. You now have the basic hexagonal beam shape established.

5. Wire/Tip Spacer Assemblies

A. **Do not over tighten the wires.** The wires should be a little slack. It is not necessary for the wires to be taut for the beam to perform as it is supposed to perform.

B. Begin with the 10 meter Wire/Tip Spacer assembly (or the highest frequency band provided) and repeat for each of the bands with the lowest frequency band last. The lowest band will be the longest wire assembly. The wire/tip spacer assemblies are already adjusted exactly for each band and no adjustment of their length is required.

Tip: To keep them from getting tangled up lay the wire assembly out along the ground unraveled and then start threading it through the attachment hardware carefully starting with spreader No 1. Shaking the wire can unravel a lot of tangles. It wants to come loose!

C. The 10 meter wire assembly uses the attachments nearest the center post unless six meters is provided in which case the six meter wire assembly uses the innermost attachments.

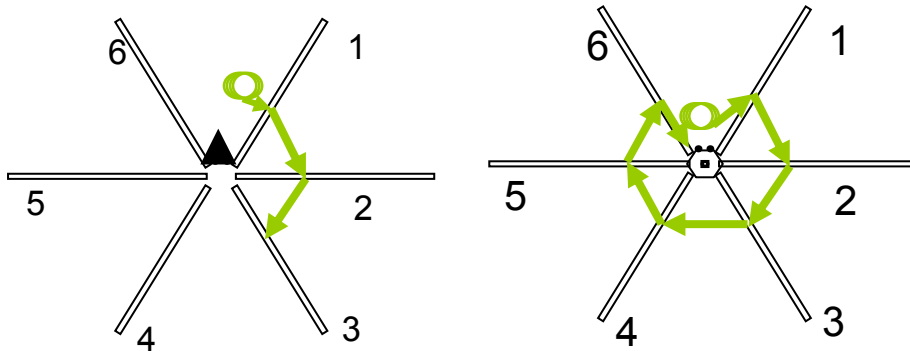

D. When the assembly is pulled through the clamp attachments around all six spreaders you are ready to connect each of the two ends to the 10 Meter terminal.

E. Pull the ends with the lugs in toward the center post and connect them to the bottom terminal. There might not be enough slack to do this easily so just loosen the clamps on Spreaders 1 and 6 and let them slip in toward the center post to allow you to make the terminal connections. Tighten the dome nuts on the bolt terminals.

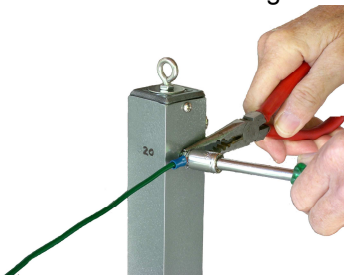

Be careful here not to allow the bolt itself to twist. Use a small wrench or pliers to hold the hex nut while tightening the dome nut as shown below. Do not over tighten; just get it snug.

The wire/tip spacer assembly looks like this when viewed from above after being installed on the frame.

20 Meter Broadband Hex Wires and Spacers (pvc ins.)
Top View, Spreaders are not shown

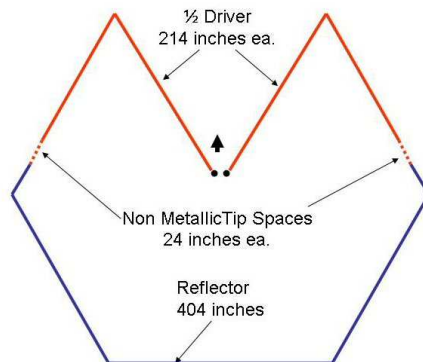

F. Repeat this process for all the other bands until all wire assemblies are installed.

G. Now begin re-adjusting the clamps that were loosened to allow you to connect the wires to the terminals. **Do not over tighten the wires** as this will distort the beam shape.

H. When complete, look at the wires to see if any are too taut or loose. You can tell if the wires are too taut by whether the support cords are sagging. If they are sagging, then you have a wire too taut. The support cords are supposed to handle the tension created by the bent spreaders. On the other hand if the wires are drooping you can take up the slack by moving all the clamps outward equally for that wire. If you need to move any clamps for a band, move them by small amounts, say $\frac{1}{4}$ inch, until you are satisfied.

I. Remember, having taut wires might look better but it will not improve beam performance. It is better to have the wires just a slight bit slack than too tight as this reduces stretching of the wires and unnecessary tension on the wire/tip spacer joints.

J. Use the remaining small support cord to attach with the cable ties to Spreaders 1 and 6 to pull them back into shape. This cord should be located at about the 15 meter wire and can be looped over the clamps at that location.

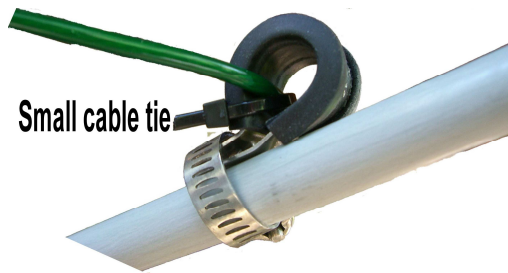

K. After you are satisfied with the shape of the beam and all adjustments of the wire clamps on the spreaders are finalized, it is a good idea to fasten the wires to the P clamps for 20 meters only so as to help stabilize the spreaders in windy conditions. Use the small cable ties as shown to fasten the wires to the p clamps on only the four back spreaders (2, 3, 4, 5).

L. The last step before raising the hexagonal beam upon your mast is to conduct a continuity test from the center of the SO 239 socket to the bottom insulated terminal. You should have zero DC resistance. Also check across the center of the socket to the outside of the socket to be sure there is no short anywhere. Of course, the transmission line should not be connected for these tests. This is a simple test and can save you a lot of aggravation of having to bring the antenna back down in the event there is a problem.

You should use coax seal when connecting your transmission line to the hexagonal beam to keep moisture from contaminating the coax line. Route your transmission line down through the hole in the base plate.

You are finished assembling the G3TXQ broad band hexagonal beam.

CAUTION

This beam is rated for the legal limit. Running power in excess of the legal limit or operating the beam on bands not equipped on your beam can cause excessive voltage and arcing of the terminals on the center post. Operating in such a manner voids the warranty and parts damaged in so doing are replaceable at full cost including shipping, to the user.

SWR tests:

You should hook up an SWR test set such as the MFJ 259B and check the beam out for SWR before elevating the beam to its final position on a tower or mast. If you do not have a test set, the internal SWR indicator in your transceiver can be used although generally these are not as accurate as test sets. Just connect the beam to the transceiver and be careful. Power applied to the beam results in harmful voltage levels on the terminals so use low power for tests with the transceiver. You should remember that SWR depends on the height of the beam above ground. Normally, on the test stand a few feet above ground, you should be able to see a dip in SWR for each band and the lowest point will be probably in the 2-3:1 range. When you elevate the beam to the operating height, hopefully at least 20 feet, you should see much better SWR across all bands.

Troubleshooting:

If you cannot get SWR readings that are in the 2-3:1 range on the test stand, check the following:

- All wires are snugly connected to their terminals.
- The test set is connected properly to the hexagonal beam with a PL 259 type coax connector.
- Make sure all wire assemblies are properly strung on the spreaders, none should be touching each other. Don't look for minor assembly issues like uneven spreaders or the like. You don't have to have a perfect looking beam for it to work just fine. The wires are the main thing.

Use of a common mode choke balun:

When an unbalanced feed line such as coax feeds a balanced antenna such as a hexagonal beam, common mode currents will flow on the outside of the coax. This effectively creates radiation causing a distortion in the antenna's radiation pattern. You might have this and be unaware of it as the SWR is usually unaffected. The easiest way to combat this is to use a common mode choke balun such as the ones we offer (BAL-8 and BAL-58). This balun can be located just below the SO 239 coax connector at the top of the center post or below the base plate. Other baluns such as those sold by MFJ, Palomar or DX Engineering are quite acceptable as well.

**Coupling to the Mast:
Regular bottom flange**

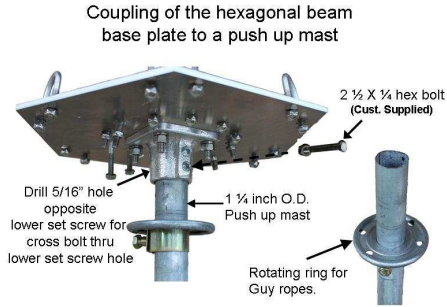

Optional large bottom flange

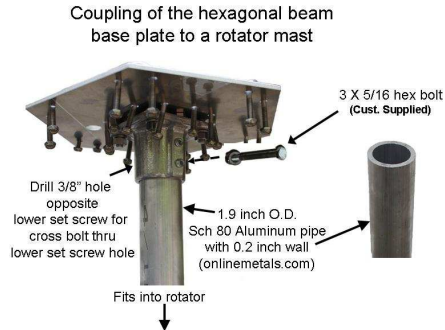

To prevent free wheeling of the beam when the bottom flange set screws work loose, drill through the bottom flange set screw hole and the top of the mast and insert a cross bolt as shown above. This is better done by drilling the hole after the beam is set down into the mast so the holes will line up correctly. A hand drill is adequate for this as the flange is a relatively soft alloy.

Other Rotator and tower considerations:

A push up mast is completely adequate to hold the hexagonal beam. However, you will need to guy it properly. Proper safety measures should be observed if using a tower.

Attach the coax transmission line to one of the spreaders about 1 – 2 feet out from the center using a cable tie to allow it to rotate with the beam and avoid tension on the coax connector on the center post. Allow a couple feet of slack between the center and the attachment to the spreader.

Specifications of Hexagonal Beam by K4KIO

Band	1/2 Driver wire	Reflector wire	Tip Spacers
20	214.0	404.0	24.0
17	166.0	314.5	18.5
15	142.9	271.8	16.0
12	119.25	227.25	13.5
10	104.5	200.25	12.0
6	59.5	114.4	6.5

Weight 25 lbs
 Diameter 21 ft.
 Ht. <38 inches
 Wind Surface Area < 5 sq. ft.
 SWR < 2.0:1
 Forward Gain, maximum 5 dBi
 Front/Back ratio, min. 10 dB